

# Let us turn your needs into mobile robotic solutions

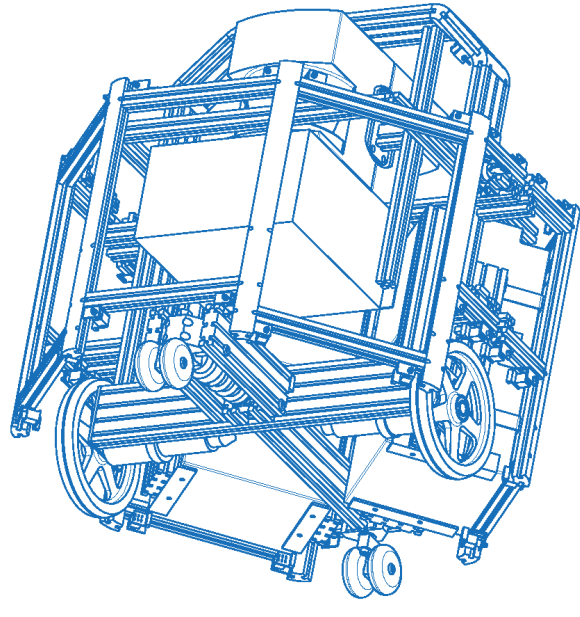
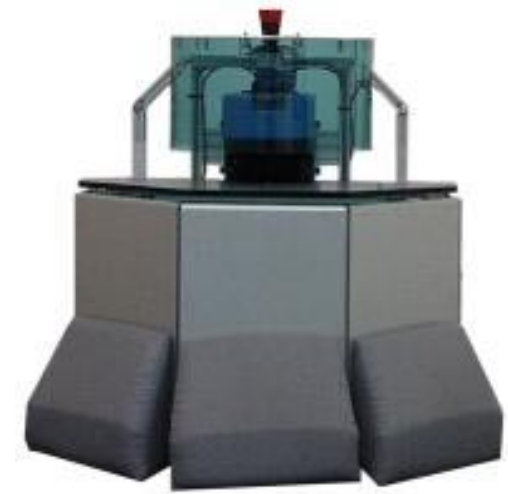

## MB835

The MB835 mobile base is the result of years of experience and direct interaction between robot designers and mobile robotics researchers.

- Diameter: 70 cm
- Height: 70 cm
- Weight: 100 kg
- Payload: 50 kg
- Autonomy: 10-12 hours

### Sensors

- 500 pulse/rev encoders with 1/50 Harmonic Drive reduction
- Eight full body tactile zones
- Two SICK LMS-200 laser scanners

### Actuators

- Two high torque 24V EC motors

### Processing

- Motorola PPC750 & optional Intel PIII I/Os
- Free digital/analog I/Os & RS422/232

bluebotics.com



**INDOOR  
TRANSPORTATION**

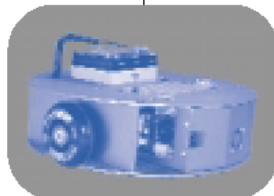

**RESEARCH**



**SURVEILLANCE**



**ENTERTAINMENT**